

Tehnički podaci :

Snaga maksimalna	9 W
Snaga nominalna	6 W
Izvodi snage 100 V	6 / 3 / 1,5 / 0,75 W
Izvodi snage 70 V	3 / 1,5 / 0,75 / 0,375 W
SPL (1W/1m, 100Hz-10kHz)	91 dB
SPL (1W/4m, 100Hz-10kHz)	79 dB
SPL (6W/4m, 100Hz-10kHz)	88 dB
Frekvencijski odziv	180 – 20.000 Hz
Disperzija	175°
Ulazni napon	70 / 100 V
Impedancija	1,7 kOhm / 3,3 kOhm / 6,7 kOhm / 13 kOhm
Priključak	Keramička stezaljka
Dimenzije	181 × 129 mm
Težina	1,29 kg
Boja	Bijela RAL 9003 i crvena RAL 3000
Stupanj zaštite IP	IP21
Termički osigurač	150 °C
Veličina zvučničke jedinice	5"
Radna temperatura	-25 do 55 °C
Radna vlažnost	< 95 % RH
Certifikat	EN 54-24

Dimenzije

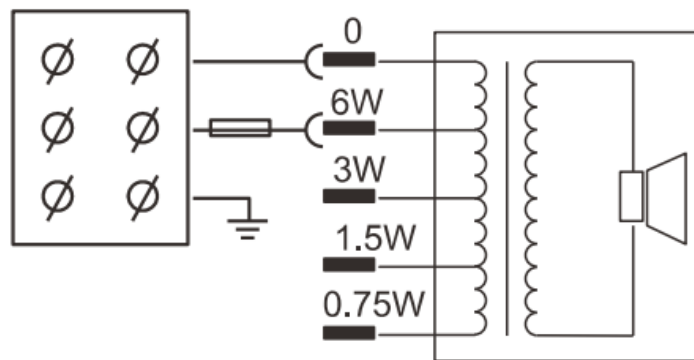
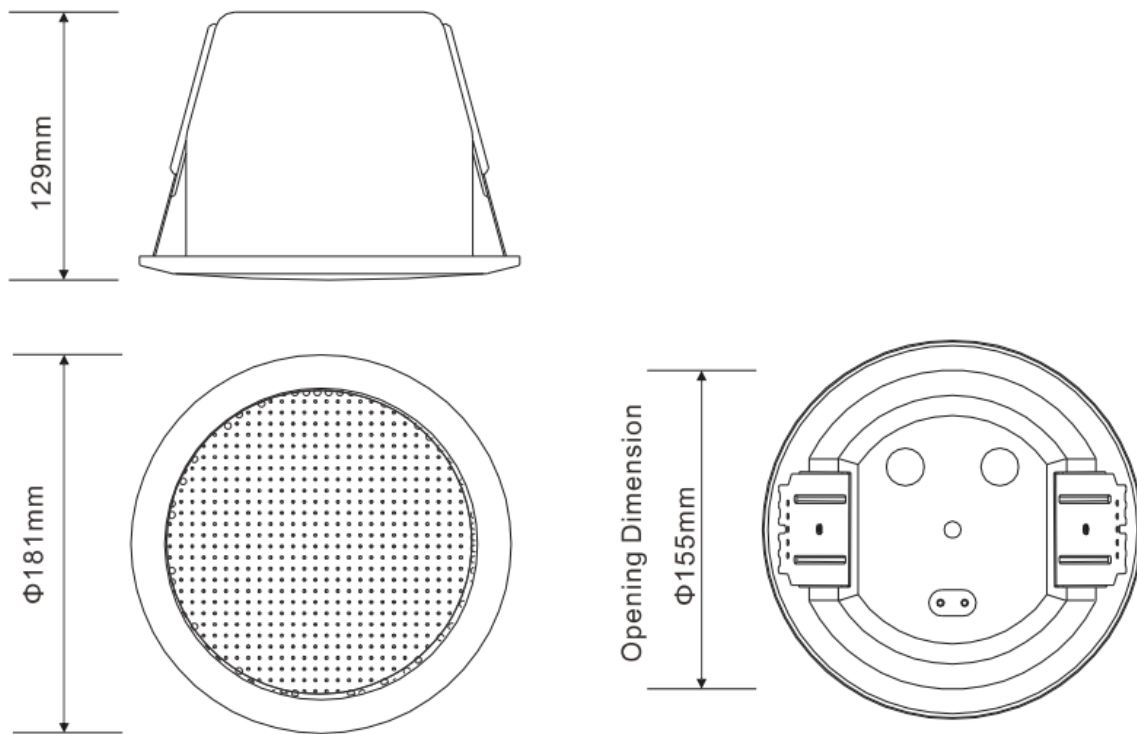

Frekvencijski odziv

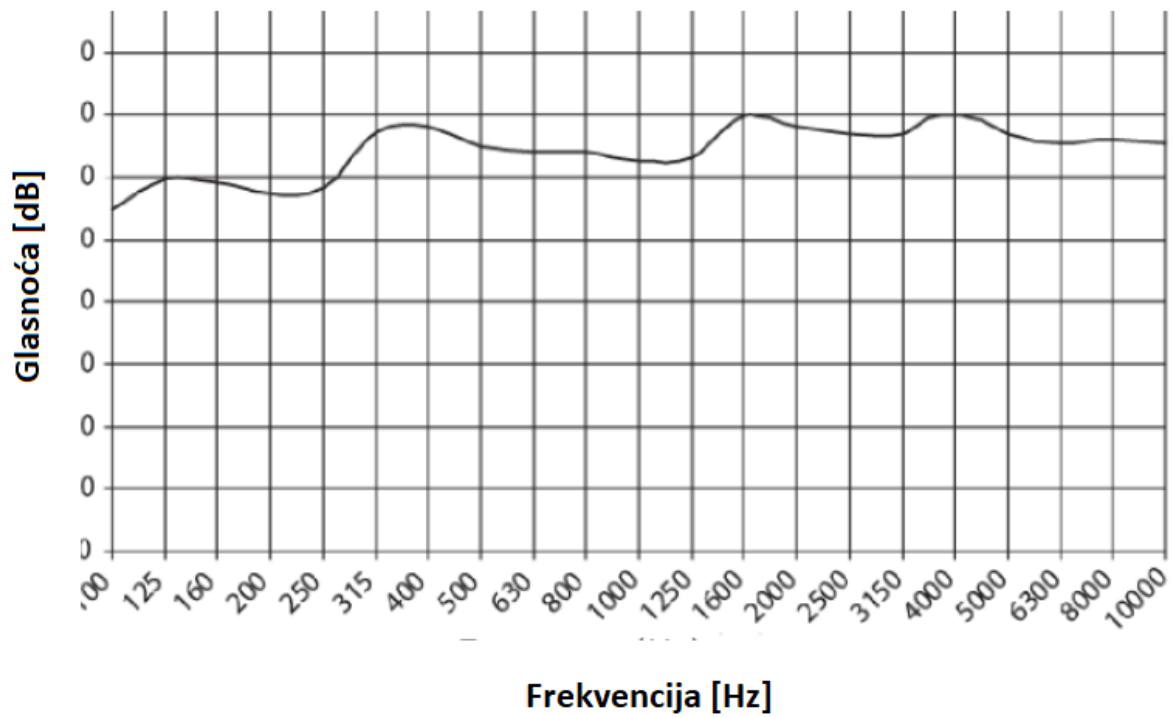

Polarni dijagram

